

# Madvac® 61 Vacuum Litter Collector Specifications

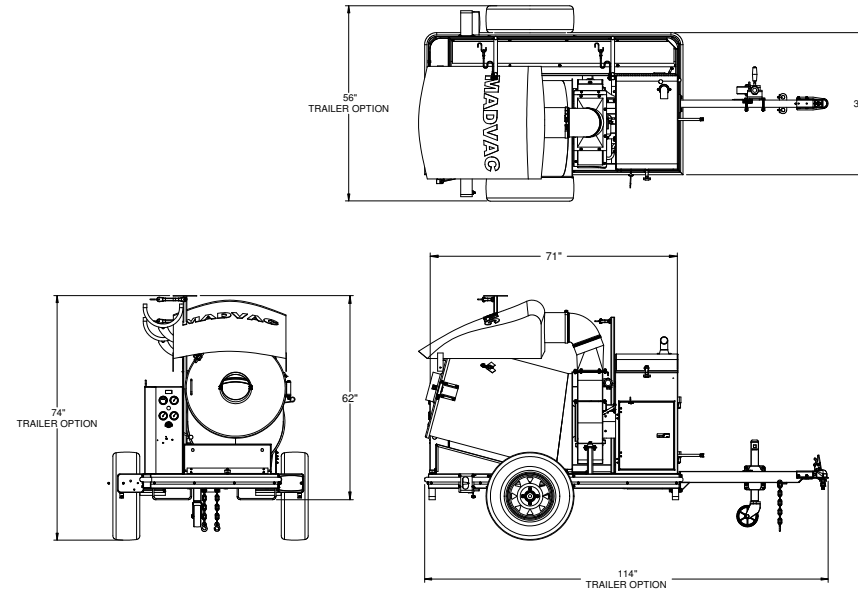

**exprolink**  
A Viconnex Company

## Data and Performance Information

Capacities	
Fuel Tank	6 Gal. (22.7 L) 24 hours autonomy
Litter Capacity	100-120 gal (378L - 454 L)
Engine Data	
Model	Kubota diesel Z482-E3B
Displacement	29.3 cu in, (479 cc)
Gross Rated Power	13.3 hp (9.9 KW) @ 2800 rpm
Legislation Compliance	EPA Tier 4 / Euro 4
Air Filter	2 stage Donaldson type
Litter Collection System	
Type	System "Flow Trough" with approx. 2 to 1 compaction ratio, with reusable fibrous bag
Container Construction	16 gauge powder-coated steel
Vacuum Hose	5 in (127mm) OR 8 in (203 mm)
Frame/Body	
	Heavy gauge steel body on a welded ¼ in. structural steel frame
	Storage compartment
	Electrostatic powder-coated paint
Vacuum System	
Vacuum Rating	2900 CFM ( 82.12 CMM )
Air Flow	8,400 ft./min (237.8/M/min)
Static Pressure	30 In water gauge (7.472 KPA)

Electrical	
Voltage	12 Volts, 40 AMP alternator and heavy duty battery
Instruments	
	Ammeter, hour, fuel, oil pressure, water temperature gauges and glow plug light
Lighting	
	Strobe light
Skid	
Length	71 in. (1803 mm)
Width	39 in. (82.55 mm)
Height	62 in. (1575 mm)
Weight	700 lbs (322.1 Kg)
Trailer	
Wheels	(2) 175/80 R 13, radial 4 seasons
Lighting	
	Complete signaling package
Length	114 in. (2896 mm)
Width	56 in. (1422 mm)
Height	75 in. (1880 mm)
Weight	910 lbs (412.8 Kg)



Madvac® 61 - Clean-up and save money

**Montreal Office:** 667, Giffard Street  
Longueuil (Quebec)  
CANADA J4G 1Y3

**Toll Free 1 855 651-0444**  
Tel. 450 651-0444  
Fax. 450 651-0447

[www.exprolink.com](http://www.exprolink.com)

[www.exprolink.com](http://www.exprolink.com)

## Madvac® — The litter collector benchmark

Madvac® is the world's leading manufacturer of outdoor surface cleaning equipment. We are unique among vacuum manufacturers in that our comprehensive range of machines means we are able to offer the right product for your application – whatever you are trying to clean.

The Madvac® 61 is designed to deliver industry-leading vacuum litter collecting technology:

- Ease of use
- Outstanding performance
- Reliability, durability
- The lowest possible cost of ownership

With durable, rugged construction, high performance suction and a design that meets all international safety and environmental standards, the 61 sets the global benchmark for vacuum litter collector quality.

40 ft (12 m) hose and optional vacuum hose arm gives you the reach you need for hard-to-reach areas.

## From landfill to shopping sites

### Clean up the savings

One Madvac® 61 does the job of 4 to 5 manual pickers. Our machines have made the old-fashioned manual litter collection methods a thing of the past. The 61 can do the job of a vanload of people. It's there, when you want it... and it's always productive.



### Incredible mobile suction

Get to the hard-to-reach areas quickly with the amazing portable Madvac® 61 litter collector. It fits on a pickup truck or hitches as a trailer and sucks up windblown trash from fence lines, parking lots and parks with hose length of up to 40 ft (12 m).

Easy to maintain, even easier to operate, and engineered to last... this is the most cost effective approach to litter collection.



**BELOW**  
Clean up anywhere, anytime  
**BOTTOM**  
Cleans fence lines four times faster than manual pick-up

## Increases productivity by 400%

### From landfill to shopping sites

- 5 or 8 inch (127 or 203 mm) diameter hose
- Optional 5 inch (127 mm) 40 ft (12 m) hose extension for extra reach
- Air exhaust filter bag keeps operators dust-free
- Vacuum compacts litter 2:1 ratio resulting in 100-120 gallons (378-454 L) capacity steel container
- Patented straight-through suction compacts litter yielding approx. 160 gallon (600 L)
- Quick-change litter bag
- Vacuums cans, bottles, newspapers, plastic and paper bags as well as other trash

### No Fan to Jam

- No Fan To Jam™ patented straight-through suction prevents trash from going through the fan - eliminating fan wear, clogging and mechanical downtime
- Uses variable suction control
- Reliable, powerful workhorse powered by either a Kubota diesel engine, Kohler gasoline, Kohler propane or electrically
- Easy access to engine compartment for simplified maintenance
- Lifetime warranty on the fan
- Trailer to skid-mount in 15 minutes

